

Microstep®

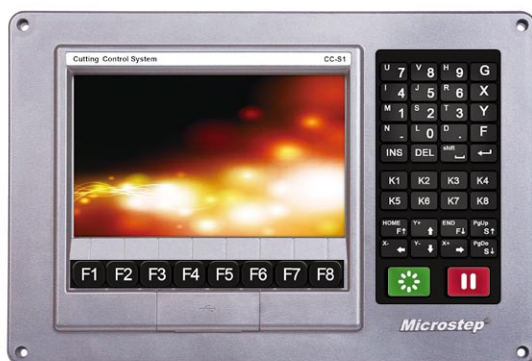

CNC Cutting Controller CC-S1 User Manual

www.microstep.cc Tel : 86-010-88909210/88909235 Fax : 86-010-88909271 E-mail: main@microstep.cc

Microstep®
START®
SHAPHON® 斯达特

北京欣斯达特数字科技有限公司
Beijing Flourishing Start Digital Technology Co.,Ltd

Contents

| | |
|-------------------------------------------------------------|----|
| Safety notice..... | 1 |
| Safety operation..... | 1 |
| Mechanical dangerousness..... | 1 |
| High-voltage dangerousness..... | 1 |
| Power isolation..... | 1 |
| Working environment..... | 1 |
| Controller connection..... | 1 |
| Good ground-connection..... | 2 |
| Controller protection..... | 2 |
| Others..... | 2 |
| Controller operation and maintenance..... | 2 |
| Controller operation..... | 2 |
| Controller maintenance..... | 2 |
| Declaration..... | 2 |
| Controller guarantee instruction..... | 2 |
| Chapter 1 Controller functions overview and main menu..... | 3 |
| 1. Controller functions..... | 3 |
| 2. Controller features..... | 3 |
| 3. Hardware technical parameters..... | 3 |
| 4. Controller main menu..... | 3 |
| 5. Main menu instruction..... | 4 |
| Chapter 2 Auto function..... | 4 |
| Options instruction of Auto interface..... | 4 |
| 2.1 enter process interface of Auto | 4 |
| 2.2 enter Man (manual) interface..... | 6 |
| 2.3 enter Sectio (section) interface..... | 8 |
| 2.4 enter BreakP (breakpoint) interface..... | 9 |
| 2.5 enter Figure interface..... | 9 |
| 2.6 enter Upload interface..... | 10 |
| 2.7 enter Assist interface..... | 10 |
| 2.8 enter BackRe (backreference) interface..... | 11 |
| Chapter 3 special instruction during automatic cutting..... | 11 |
| Chapter 4 Edit function..... | 13 |
| Options instruction of Edit interface..... | 13 |
| Chapter 5 Param (parameter) function..... | 14 |
| Options instruction of Param (parameter) interface..... | 14 |
| 5.1 enter System interface..... | 14 |
| 5.2 enter Speed interface..... | 15 |
| 5.3 enter Ctrl (control) interface..... | 16 |

| | |
|---------------------------------------------------------------------------------|----|
| 5.4 enter Craft interface..... | 17 |
| Chapter 6 Diagn (diagnosis) function..... | 19 |
| Options instruction of Diagn (diagnosis) interface..... | 19 |
| Chapter 7 Figur (figure) function..... | 21 |
| Options instruction of Figur (figure) interface..... | 21 |
| Chapter 8 Help function..... | 22 |
| Options instruction of Help interface..... | 22 |
| Chapter 9 Control code..... | 23 |
| Coordinate..... | 23 |
| Program..... | 23 |
| G code..... | 23 |
| M code..... | 26 |
| Radius compensation..... | 28 |
| Chapter 10 Controller input/output connection..... | 28 |
| 10.1 Controller input principle..... | 28 |
| 10.2 Controller output principle..... | 29 |
| 10.3 Controller input/output definition..... | 29 |
| 10.3.1 DB25 input definition..... | 29 |
| 10.3.2 DB15 input definition..... | 31 |
| 10.3.3 15-pin motor port..... | 31 |
| 10.3.4 Flame cutting connection (DB15)..... | 31 |
| 10.3.5 Plasma cutting connecton..... | 32 |
| 10.3.6 Flame/plasma integration..... | 32 |
| 10.4 Output connection..... | 32 |
| 10.4.1 Output principle..... | 32 |
| 10.4.2 Notice..... | 34 |
| Chapter 11 Common faults and solutions..... | 34 |
| 11.1 Controller fault..... | 34 |
| 11.2 Operation fault..... | 34 |
| 11.3 Program fault..... | 34 |
| 11.4 Controller functions declaration..... | 35 |
| Appendix 1: Optional Parts..... | 35 |
| Appendix 2: Torch height controller (SH-HC30) connection..... | 35 |
| 1. Arc-voltage & capacitive torch height controller integration connection..... | 36 |
| 2. Voltage divider board (9 pins) definition..... | 36 |
| 3. Arc-voltage torch height controller connection..... | 36 |
| 4. Capacitive torch height controller connection..... | 37 |
| Appendix 3: remote control connection definition..... | 37 |
| Appendix 4 : CC-S1 upgrade operation..... | 37 |
| Appendix 5: Installation Dimension..... | 38 |

Safety notice

Please carefully read the manual before using this controller.

Safety operation

Please read the safety notice and understand how to use the controller and make necessary safety protection measurements. Please contact us if you have other requests.

Mechanical dangerousness

Operation and repair of automation equipments are a little dangerous and are careful. Please be far away from the working equipment. Please control the equipment by correctly using the panel' s buttons. Don' t wear so loose clothes when using and repairing the equipment.

High-voltage dangerousness

Be careful of electric shock during operation. Please install the equipment according to its manual. Don' t touch cables or wires after power on. Only professional maintenance personal can open the controller. When the equipment has problems, power should be off and then repair.

Power isolation

Please check whether power is $AC220V \pm 15\%$.

AC stabilized-voltage power is a must if power is beyond the above range.

In some places there is no normal power, such as zero wire and ground wire are together or no zero wire, an isolation transformer must be used from 2-phase/3-phase AC380V to 2-phase AC220V.

A lightning rod is also a must.

Working environment

The controller' s working temperature is 0-40°C. If out of its working temperature, the controller probably works worse. If the temperature is below 0°C, the screen will not display normally.

Relative humidity is 0-85%.

Special protection is a must when working in high-temperature, high-humidity, and corrosive-gas environment.

Don' t ask dusts, metal chips and others to go into the controller.

Controller connection

The controller' s input/output uses 24V DC power (3A or over 3A) and the power can' t be used for other electrical equipments. When the power is not connected and emergent stop and limit position are both valid, the controller will in the state of emergent stop and limit position.

The connection wire between the controller and the driver should be shielding wire.

Don' t plug in and plug out when power on.

Controller' s input/output wire should connect well.

Good ground-connection

All parts of the cutting machine and the controller should connect ground.

Controller's ground wire diameter should be over 4 mm², and try to keep a shorter distance to the ground.

DC24V ground (-) must break with ground.

Controller protection

Don't ask dusts, metal chips and other materials to go into the controller so that it can't normally work.

The controller's LCD screen should be protected.

Others

The controller can use U disk and its format is FAT or FAT32

The controller has a manual.

If the controller damages because of abnormal operation, we are not responsible for maintenance.

Controller operation and maintenance

Only professional operators can use the controller.

Controller operation

Please use fingers to press buttons.

Please don't change functions and parameters at random if you are not familiar with them.

We offer controller operation training for free.

Please feel free to let us know your operation problems.

Controller maintenance

When the controller can't work normally, you need to check relative hardware or wire connection after power off.

Don't open the controller to repair without professional personnel.

Please feel free to let us know when the controller has problems.

Declaration

Controller guarantee instruction

Guarantee period: within 12 month after leaving our company.

Guarantee terms: during guarantee period any problems under normal operations.

During guarantee period, we charge out of guarantee terms.

We charge for all problems out of guarantee period.

Following situations are beyond guarantee

Any damage under abnormal operation or accident damage;

Damaged by plug in and out controller when power on;

Natural disasters;

Repair, disassemble, retrofit, etc. at random without our allowance.

Chapter 1 Controller functions overview and main menu

1. Controller functions

CC-S1 CNC cutting controller is used for flame and plasma cutting machines.

2. Controller features

1.2.1 CC-S1 CNC cutting controller is used for flame and plasma cutting machines.

1.2.2 It has a reliable design, anti-plasma interference, lightning proof and surge proof.

1.2.3 It has perfect flame/plasma cutting technology. Corner speed control is automatically finished when plasma cutting. It can work with the torch height controller and remote control.

1.2.4 Kerf compensation function.

1.2.5 Automatically remember breakpoints, breakpoint recover; automatically recover after power off, record latest 3 breakpoints.

1.2.6 Choose any section and pierce point to cut.

1.2.7 Outside edge pierce for thick plate, bridge for thin plate.

1.2.8 Pause, backward, forward during cutting any time, more convenient.

1.2.9 Change cutting anytime.

1.2.10 Special small section cutting is smoother.

1.2.11 There are 24 common figures in part library.

1.2.12 It's compatible with IBE, FASTCAM and other nesting softwares.

1.2.13 Dynamic figure display, 1~8 times of figure zoom in, automatically follows by point.

1.2.14 Big store space of 4G, it can contain 10000 programs, support folder management.

1.2.15 Read programs and controller upgrade by U disk.

1.2.16 Perfect cutting parameters settings, including parameters backups, input and output as well as settings in bulk.

1.2.17 Multi-level management permission setting and set operation permission according to the date.

3. Hardware technical parameters

Processor: industrial ARM processing chip

Screen: 7" color LCD

Input/output: 13 optical isolation input, 8 optical isolation output

Axis: 2 axis, 4 axis is available

Pulse equivalent: electrical gear numerator & denominator range (1 ~ 65535)

store space: 4G

Working temperature: 0°C ~ +40°C

Store temperature: -40°C ~ +60°C

4. Controller main menu



5. Main menu instruction

Controller version number: current version information

[F2] Auto: automatic cutting program control

[F3] Man: manually adjust torch

[F4] Edit: edit/revise/USB input/output cutting program

[F5] Param (parameter): controller parameters set

[F6] Diagn (Diagnosis): check machine input/output state

[F7] Figur (figure): figures library

[F8] Help: help information of every function

Chapter 2 Auto function

Options instruction of Auto function

[F1] Exit: exit Auto operation

[F2] Man (manual): change to manual operation

[F3] Sectio (section): change to section operation

[F4] BreakP (breakpoint): breakpoint operation

[F5] Figure: figure operation

[F6] Upload: upload program

[F7] Assist: assist operation

[F8] BackRe (back to reference): enter operation of back to reference

2.1 Enter Auto interface

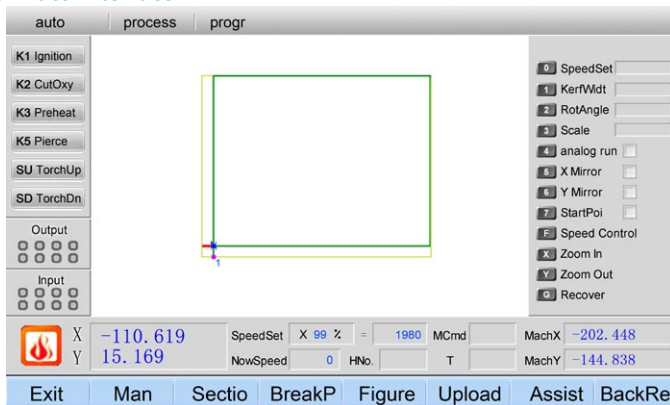

2.1.1 [0] SpeedSet: directly adjust speed parameters of cutting the current program (IdleSped (speed of idle running (no load), CutSpeed (running speed), ManSpeed (speed of manual operation), BackSped (speed of backward operation)).

Note: If current speed settings is not bigger than max. speed (idlespeed) of the parameter interface, speed settings of parameter interface will not be changed. If bigger than speed settings of parameter interface and less than max. speed, speed settings of parameter interface will be change. If bigger than speed settings of parameter interface, then run based on max. speed.

2.1.2 [1] KerfWid (kerf width): kerf compensation, 0 is for no compensation, press [ENTER] to confirm and save (It's better to set kerf compensation in nesting software). If the program has G41 or G42, and choose "G41/G42 is valid" in CTRL, the kerf width is valid. The parameter will keep the same till next change. It's an important parameter to affect cutting size and check it before cutting.

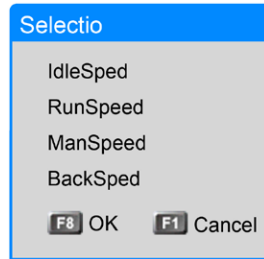

2.1.3 [2] RotAngle (rotation angle): set the figure's rotation angle, default is 0, no rotation. The parameter will keep the same till next change.

2.1.4 [3] Scale: set figure's scale, default is 1, the actual figure is the same big as cutting figure (the scale is changed based on last scale). It will return to 1 after exit AUTO cutting.

2.1.5 [4] Idle Run: analog cutting at idle run speed. There is no output control. Speed adjustment, torch lifting and others are valid. External input is valid (emergent stop, limit position, etc); The parameter will keep the same till next change.

2.1.6 [5] X Mirror: figure's mirror for X axis. The parameter will keep the same till next change.

2.1.7 [6] Y Mirror: figure's mirror for Y axis. The parameter will keep the same till next change.

2.1.8 [7] StartPoi (change start point): change torch's initial position (X mark is initial position out of figure). The parameter will keep the same till next change.

2.1.9 [F]: Adjust multiplying power: during cutting, press F, then press any number button (1~9) to adjust speed multiplying power, for example, press F and 1, current speed changes to 10%, press F and 0, change to 100%. This function is to adjust current speed, if this moment it's G00, G00 speed multiplying power will be adjusted.

2.1.10 [X] Zoom In: zoom in the figure (at most operation 3 times, 8 times of previous figure)

2.1.11 [Y] Zoom Out: zoom out the figure (at most operation 3 times, 1/8 times of previous figure)

2.1.12 [G] Recover: recover the figure to previous size

2.1.13 [Start]: green button, press it to automatically cut the figure

For flame cutting, when preheat to press [Start], preheat can over in advance, the controller will record the sum of preheat time for next pierce, when torch lifting and ignition and other delay time to press [Start], they can over, but don't change future delay time.

2.1.14 [Pause]: pause the cutting

When cut to pause, whether the torch rises according the option of "torch rises after pause". For flame cutting, torch stops moving and cutting oxygen is closed and keep gas and preheat oxygen output (flame doesn't break); for plasma cutting, torch stops moving and plasma power arc strike signal is closed.

For flame cutting, when preheat delay time to pause, the controller will increase 100s of preheat time, press [Start] to over preheat, then begin to pierce and cut. The controller records the sum of preheat time for next pierce, or directly press pierce button to over delay time, begin to pierce and cut, doesn't accumulate preheat time, previous preheat time is valid for next pierce.

Following situations can bring pause during auto cutting

A) external pause of input port is valid

B) for plasma cutting, choose “arc voltage check” in PARAMETER to cause pause when arc breaks.

C) Choose ‘torch collision check’ in PARAMETER, and controller’s input port has signal, it will pause

After pause, there are some options as below,

[0] Forward: idle run to continue

[1] Back (backward): idle run backward along previous track

This option is usually used for arc break and flame break, near the break point, choose proper position to pierce and cut again, speed forward and backward is set in SPEED interface.

[2] HolePoin (pierce point): input the pierce number, you can choose “ToThePoint/Local Run”. “ToThePoint” is move to the pierce point from current position; It’s for giving up current section, restart from the specified pierce point. “Local Run” is to make torch position as pierce point. It’s for changing new plate, continue to cut from selected pierce point.

[3] SpeedSet: set speed parameters (IdleSped (speed of idle running (no load), CutSpeed (running speed), ManSpeed (speed of manual operation), BackSped (speed of backward operation))

[4] Zoom In: zoom in the figure

[5] Zoom Out: zoom out the figure

[6] Idle Run: analog cutting at idle run speed. There is no output control. Speed adjustment, torch lifting and other operation are valid. External input is valid (emergent stop, limit position, etc.)

[7] ContMove (move continuously): move continuously after press direction buttons, press reverse direction button or Pause button to stop

[8] BackRefe (backference): back to workpiece reference point

[F1]: Exit: controller automatically records a break point, and continue to cut by the option of “find break point”

Note: after moving torch, press [Start] again, the controller will tip (Back/Cut Back/Continue) to choose different cutting mode. This function is for changing nozzles, temporary edge pierce, transfer cutting and other special situations.

2.2 Enter Man (manual) interface

2.2.1 [0] DriftAngleStar (drift angle start point)/[1] DriftAngle End (drift angle end point): start point and end point of steel plate calibration (choose a longer side of steel plate), press [0] to set start point, move torch to another point, press [1] to automatically calculate steel plate calibration angle, and automatically rotate figure.

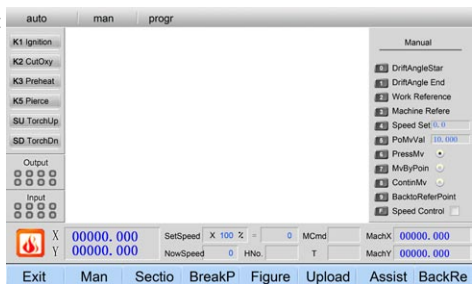

2.2.2 [2] Work Reference (workpiece reference point): make the current coordinate as reference point of parameters.

2.2.3 [3] Machine Refere (machine reference point): make current machine position as machine zero point, and machine coordinate clears zero.

2.2.4 [4] Speed Set: set manual speed, press [ENTER] to confirm and input values.

2.2.5 [5] PoMvVal (increment value of point movement): set the increment value of point movement, press [Enter] to confirm and save, at the same time you must choose [7] MvByPoin (point movement), it' s the mode of point movement.

2.2.6 [6] PressMv (move after press)/[MvByPoin] (point movement)/[8] ContinMv (move continuously): [6] is to run motors when press X/Y direction buttons, vise versa; [7] is to run the value of [5] when press X/Y direction buttons one time (value of [5] has the same unit of coordinate value); [8] is to run motors when press X/Y direction buttons one time, if press the reverse direction button of the same axis, motor stops; if press another axis, two axis linkage; if stop one axis, press the reverse direction button of its moving direction; red Pause button stops all movement, (pause during point movement, restart point movement, increment value is still valid).

2.27 [BacktoReferPoint] (back to reference point): processing start point, not cutting start point

2.28 [F] multiplying power adjustment: during cutting, press F, and then press any number of 1 to 9 to adjust relative multiplying power. For example, press F and 1, current speed becomes 10%, press F and 0, speed multiplying power is 100%.

Strong electricity in manual mode

Flame

Gas and preheat oxygen usually have two kinds of connection, 1 is single connection, gas connects OH1, preheat oxygen connects OH7. One is common connection, both connect OH1.

[K1] Ignition: ignite gas, turn on the torch, and turn off it after ignition delay time is over. If gas (preheat oxygen) doesn' t open, then firstly open gas, press Preheat or K4 (total shut) close gas (preheat oxygen), if ignition fails, reopen.

[K2] Cutting: cutting oxygen, open cutting oxygen, press again to close

[K3] Preheat: open gas (OH1), press again to close. Usually a relay connects gas and preheat oxygen solenoid valve.

[K5] Pierce: without manually opening preheat in advance, controller will run a complete pierce movement.

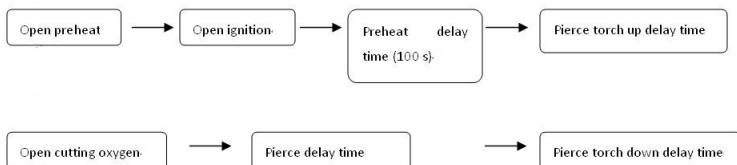

If preheat time is not enough, press [Pause] before preheat delay time is over, delay time will increase. If preheat is ok, press [Start] to over preheat delay time, and automatically save the preheat time as parameter.

Note: please check torch height before pierce, after the initial height should meet the demand of torch down delay time, the height is preheat height.

If preheat delay time open

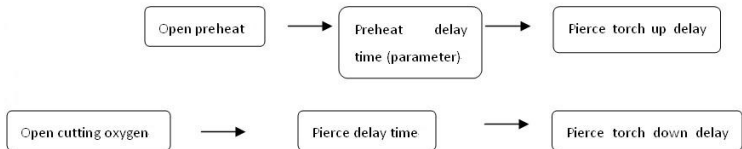

press [Start] and [Pause] to change preheat delay time

After successful pierce, manual cutting is available (press direction buttons to start)

[Del] total off: close all outputs.

Torch up and down

Plasma

[K2] strike arc: open arc-strike output

[K5] pierce: run a complete pierce movement (M07), firstly torch down (torch down delay time), then stop, open arc-strike output, torch height controller gets auto signal after pierce delay time.

If choose pierce location valid, the torch will move down till receiving torch location switch signal, then stop moving down, then moves up according to location delay time, then stop and open arc-strike output, continue next movement.

If choose arc-strike signal check, then after opening arc-strike output, wait for arc-strike successful input signal, after receiving signal, continue next movement.

2.3 Enter Section interface

2.3.1 [0] PiercePo (pierce point): cut according to pierce number, and it tips the most number of pierce point, input pierce number and press [Enter] to confirm.

There are two options, "move to the point" and "locally cut" .

"move to the point" is torch moves the selected pierce point at G00 speed

"locally cut" is make current point as selected pierce point, press [Start] to continue cutting.

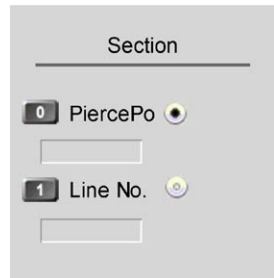

2.3.2 [1] Line No. (line number of program): cut according to the line number of program, and it tips max. line number, input program line number, press [Enter] to confirm.

There are two options, "move to the point" and "locally cut" .

"move to the point" is torch moves the selected pierce point at G00 speed

"locally cut" is make current point as selected pierce point, press [Start] to continue cutting.

2.4 Enter BreakP (breakpoint) interface

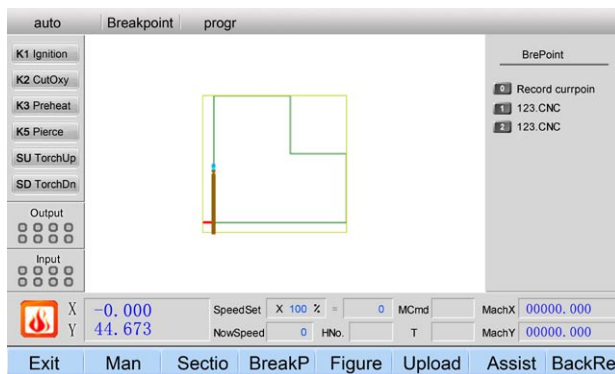

[0] Record currpoin (record current point): save current cutting position as breakpoint.
 [1], [2], [3] are breakpoints, save 3 breakpoints at most.

Note: during working, the machine stops by manual pause or blackout, the controller automatically save a break point of current torch position forever. Break point [3] is the latest record, 3 break points can be from different files, please confirm whether files have been saved when choose break points. If the file is from U disk, please confirm whether U disk connects well.

1. If the torch is moved before looking for break point, and want to continue cutting from the break point, can press [Start], and choose "general back" and continue cutting; maybe there is overburnt pierce point, you can firstly move the torch to a place near the breakpoint, then [Start], choose "cutting back", continue cutting (this function is similar with outside edge pierce).
2. If don't move the torch before looking for break point, find the break point, if cut from the point, you can press [Start] to choose "local continue", maybe there is overburnt pierce point, don't want to cut from the break point, can press F2, manually move the torch to a place near the break point, then press F1, enter auto, press [Start], choose "cutting back", continue cutting.
3. No matter whether move the torch, don't change current cutting program, rotation angle, scale (they can be automatically saved by the controller), or controller can't find the break point.

2.5 Enter Figure interface

- 2.5.1 [0] ZoomIn: zoom in the figure
- 2.5.2 [1] ZoomOut: zoom out the figure
- 2.5.3 [2] Recove (recover): recover to previous figure after zoom in and zoom out
- 2.5.4 [3] Refresh: refresh figure display area
- 2.5.5 [4] Workpiec (workpiece), [5] Track, [6] Frame, [7] PierceP (pierce point), [8] PierceNo, [9] G00, you can change their state, you can show or hide them, then press [3] to refresh the figure.

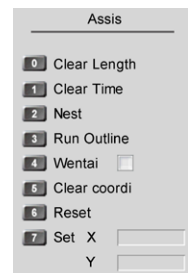

2.6 Enter Upload interface

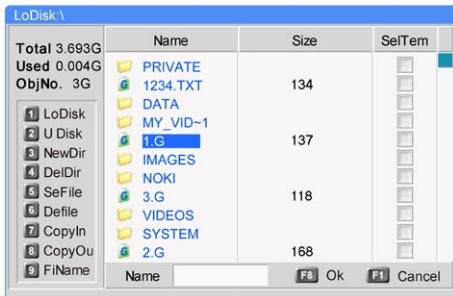

[1] LoDisk (local disk): upload program from controller' s inside disk;

[2] U Disk: upload program from U disk, press [I], [U] or [PaUP], [PaDo] to choose files, press [→] to enter files, press [←] to exit files, press F8 or [Enter] to upload program and ready to cut, press F1 to cancel.

Note: 1. this interface is only for cutting files upload, if operating [DewDir],

[DelDir] and other grey options, finish in Edit, Manage interface.before pull out U disk, change to LoDisk (local disk) state.

2.7 Enter Assist interface

2.7.1 [0] Clear Length: clear total cutting length to zero. (the function is coming soon)

2.7.2 [1] Clear Time: clear total cutting time to zero. (the function is coming soon)

2.7.3 [Nest]: nest uploaded figure in grid way

[1] Line: the number of line, minimum is 1, press [Enter] to confirm.

[2] Column: the number of column, minimum is 1, press [Enter] to confirm.

[3] LSpace (space of lines): controller automatically shows the distance of lines, you can change.

[4] CSpace (space of columns): controller automatically shows the distance of lines, you can change.

[5] Lcross (line cross): even line deviate right for odd line, default is 0.

[6] MaxWid (max. width): it works with [Lcross] (line cross), the number of parts is valid in the width range of odd line. If the value of Lcross (line cross) is 0, this option is invalid.

[7] Submit: confirm above operations to form new figure, you can save it from Edit interface.
2.7.4 [3] Run Outline: start with program cutting point, move to workpiece reference point, run around the outline to check whether cutting track is beyond the steel plate.

2.7.5 [4] Wentai: wentai is a kind of software for characters, used in advertisements.

2.7.6 [5] Clear coordi (clear coordinate): rapidly clear current coordinate.

2.7.7 [6] Reset: back to mechanical original point; when reset direction is 0, only clear current machine coordinate, don' t move machine; when reset direction is 1, machine moves along machine coordinate positive direction, touch zero point switch of controller external input, slow down to 0, machine touch zero point again along reverse direction, machine stop; when reset direction is -1, machine moves along machine coordinate reverse direction, touch zero point switch of controller external input, slow down to 0, machine touch zero point switch along machine reverse direction, machine stop. The function requires the machine to install original point switch.

2.7.8 [7] InitialCutPon: back to initial cutting point ;

2.7.9 [8] Set X/Y: set current workpiece coordinate X/Y

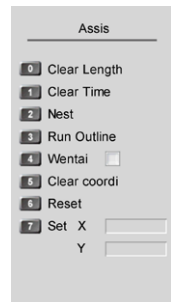

2.8 Enter BackRe (back to reference) interface

2.8.1 [Work Refer] (workpiece reference point): torch back to workpiece reference point.

2.8.2 [Mach Refer] (machine reference point): torch back to machine reference point.

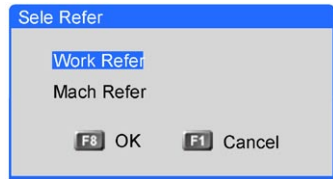

Chapter 3 Man (manual) function

3.1 speed mode (multiplying power) and start of auto cutting

3.1.1 cutting speed

When cut, it's cutting limit speed*cutting multiplying power, auto multiplying power can be adjusted by F+/F-, or press [0] to set speed, or press [F] and number keys of 0 ~ 9 to adjust multiplying power from 10% to 100%. When no cut, above 3 methods are still valid to adjust cutting speed

3.1.2 manual speed

When no cut, move the torch manually, manual limit speed*manual multiplying power, to adjust manual multiplying power, the method is the same as auto multiplying power.

3.1.3 back speed

When pause to be backward or forward, it's cutting speed*back multiplying power, back multiplying power is finished during backward and forward, by F+/F-.

3.1.4 start of auto cutting

1) before program starts

Choose proper cutting program, cutting speed (multiplying power), kerf width, rotation angle and scale (don't set if no need), then move the torch to the cutting position (after program starts, the torch will automatically move up (M70)) and others, then start auto cutting program.

2) two methods to start auto cutting

- a) press green [Start] key
- b) press [K5] key, automatically cut after pierce

3.2 control and cutting position adjustment of auto cutting

3.2.1 after auto cutting starts, following key operations are valid

- 1) [Pause]: when flame preheat delay time, press [Pause] to increase delay time of 100s, and to stop cutting, close cutting oxygen (plasma: close arc strike switch), close torch height controller (M39). You can operate following after [Pause]: (1) backward/forward along previous track, (2) adjust torch position, (3) exit
- 2) [Start]: when flame preheat delay time to press [Start], can skip preheat delay time and record the time, also can skip torch up/down delay time, but don't record delay time
- 3) [F+], [F-] speed adjustment keys: increase or decrease speed multiplying power
- 4) [S1], [S↓] control torch up/down
- 5) [F] and [0-9] adjust speed multiplying power from 10% to 100%
- 6) [Emergent stop]: it's an external key, when emergent stop is valid, all movement stop and close output for emergent situation

7) press [1], [↓], [←], [→] to move figure

8) [X], [Y], [G] to zoom in/out and recover figure size

3.2.2 cutting position adjustment

Following situations need to adjust torch position

1) torch is blocked, or need to change a new one, put torch to a safe place, then put it back the start point after change.

2) When outside edge pierce, don't hope to put the pierce point the outside of the workpiece, find a proper position at the outside of the workpiece, cut to the start point along straight line after pierce

3) Change cutting, a lot of workpieces and big size of plates, change cutting position

Following situations need to adjust cutting position

(1)pause, (2) back, (3) pierce, (4) section, (5) choose hole, (6) break point recovery

if want to change torch position during above states, can press [1], [↓], [←], [→] to directly adjust torch position (this moment is manual multiplying power), then press [Start]

3.3 Operation after pause during cutting

1. after pause, don't move torch, only forward/backward

Check pause operation, press [1] torch goes backward along previous track, if go backward so much, press [0] to continue forward, pause at the appointed position, press [Start] to continue, then there is a tip "arc/ignition"

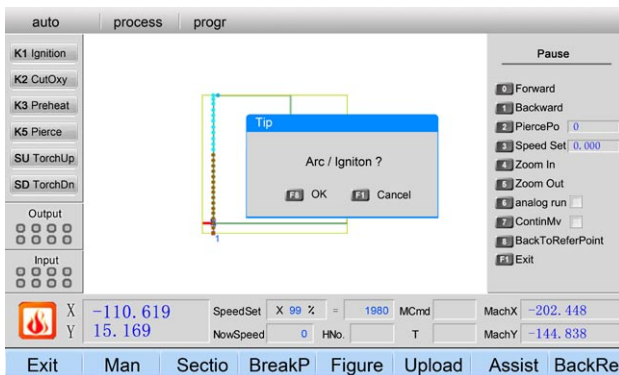

2. after pause, move torch, continue cutting

After pause, press direction keys [1], [↓], [←], [→] to move torch, then press [Start], there is a tip as below

Common Back: move torch to break point at idle- run speed, and wait for further operation, this moment can press strong-current function keys (such as ignition, preheat pierce, open cut oxygen, etc), or directly press [Start], then there is tip "arc/ignition?"

Cutting Back: pierce, cut to break point along shortest distance, continue left cutting at current speed, like outside edge pierce, to make pierce point more smooth

Local Continue: pierce, make current coordinate as "adjusting start point" coordinate, continue cutting along previous track, to change pierce.

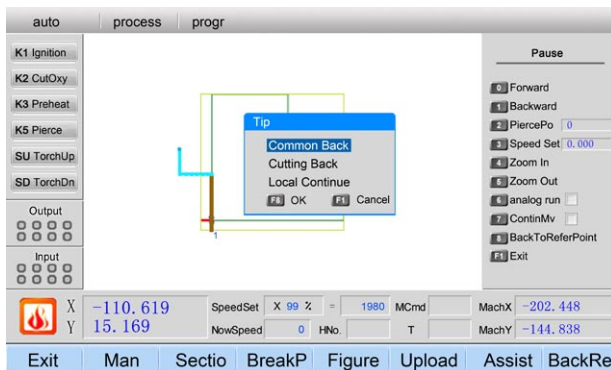

Chapter 4 Edit function

Options instruction of Edit interface

4.1 [F2] NewBui (new build): build a new program, clear program edit area, edit a new program.

4.2 [F3] Open: open a program from local disk or U disk.

[1] LoDisk (local disk): check programs and folders from controller' s disk.

[2] U Disk: U disk; check files or folders from U disk.

Press F8 or [Enter] to confirm and open program; press F1 to cancel. Before pulling U disk out, please change to "LoDisk"

4.3 [F4] Save: save program in local disk or U disk.

[1] LoDisk (local disk): controller' s inside disk.

[2] U Disk: U disk;

[3] NewDir (new directory): build a new folder.

[4] DelDir (delete directory): delete a folder.

[9] FiName (file name): name the file; F8 to confirm and save.

Note: the file with the cursor will be replaced, and the cursor will appear the first file of root directory, if save a new file, don' t name it with same name with other files.



4.4 [DelLin] (delete line): delete all contents in cursor line. Insert a new line, please press Enter

4.5 [Manage]: manage local disk and U disk.

[1] LoDisk (local disk): controller' s inside disk.

[2] U Disk: U disk.

[3] NewDir (new directory): build a new directory.

[4] DelDir (delete directory): delete a directory.

[5] SeFile (select file): select a file or folder, the option is used with CopyIn (copy in) and CopyOu (copy out).

[6] DeFile (delete file): delete file, not folder.

[7] CopyIn (copy in): current directory is in U disk, press 5 to choose a or more files or folders, press 7 to copy them to controller' s disk.

[8] CopyOu (copy out): current directory is in LoDisk (controller' s disk), copy selected file to U disk; (Note: G button is to select all; X button is to cancel all selection).

4.6 [Proces] (process) change to cutting interface, if not [Open] a program, a tip will appear.

4.7 [Figure]: change between figure and program. Preview the current figure

Note: [→] enter folder; [←] exit folder.

Chapter 5 Param (parameter) function

[Options instruction of Param (parameter) interface]

[F1]: Exit

[F2] System: important parameters of the controller, don' t change at random

[F3] Speed: set all speed parameters

[F4]: Ctrl (control): control programs and I/O functions





[F5] Craft: flame and plasma

[Switch]: change between flame and plasma

[Save]: save revised parameters

5.1 Enter System interface

| ParaName | X Value | Y Value | ValRange |
|----------------------|---------|---------|-----------|
| Gear Numerator | 0 | 0 | 1~65535 |
| Gear Denominator | 0 | 0 | 1~65535 |
| Machine Origin | 0 | 0 | -300~3000 |
| Reference Null Point | 0 | 0 | -300~3000 |
| Reverse Backlash | 0 | 0 | 0~10 |
| Soft + limit | 0 | 0 | -31000~0 |
| Soft - limit | 0 | 0 | 0~31000 |
| Reset Direction | 0 | 0 | 0~1 |
| Plate Size | 0 | 0 | 0~12000 |

| | | | | | | |
|-------------------------------------------------------------------------------------|---------------------------------------------|---------------------------------------------------------------------------------------------|-------------------------------------------------------------------------------------------------|-------|--------|------|
|  | Explain press F key to calculate gear ratio |  SpeFunc |  Upload Para | | | |
| | |  Default |  Dnload Para | | | |
| Exit | System | Speed | Ctrl | Craft | Switch | Save |

5.1.1 Gear numerator/denominator: the ratio is pulse equivalent, unit: μm (1 mm = 1000 μm), numerator < 65535, denominator < 65535.

e.g.: pulse equivalent is 0.008 mm, the electronic gear numerator/denominator = 8/1.

Electronic gear ratio calculation formula = lead screw pitch x 1000/(360 x subdivision number/step angle x drive ratio)

5.1.2 Electronic gear ratio calculation method as below,

- (1) Set an electronic gear ratio, such as 8:1
- (2) Run a command distance (the longer, the more accurate), measure the real distance, press F, input the command distance and real distance, press F8 to automatically revise current axis numerator/denominator.

5.1.3 Reference Null Point (reference zero point): program process start point, G92 automatically appears when running program, unit: mm (or inch)

5.1.4 Drawline offset: offset value of axis distance between draw-line torch and cutting torch

5.1.5 Reverse Backlash: because of machine's reverse backlash, controller will compensate backlash when change direction, backlash value is from measurement, unit: mm (or inch), usually reverse backlash is not set.

5.1.6 Soft +/- limit: when coordinate is out of soft +/- limit, alarm, if not use, parameter should be bigger than actual values, unit: mm (or inch)

5.1.7 Plate size: set plate actual size

1. gear numerator and gear denominator affect cutting size and speed
2. gear numerator is in principle bigger than gear denominator for bigger running speed (1:1 has 0.001mm of control precision). When numerator is smaller than denominator, adjust driver to make numerator bigger than denominator.
3. other parameters can choose according to the requests.

5.2 Enter Speed interface

| ParaName | Value | ValRange | Unit |
|----------------------|-------|----------|--------|
| Start Speed | 8 | 20~12000 | mm/min |
| TimeMultiplyingPower | 0 | 1~65535 | |
| Buff Speed | 0 | 20~18000 | mm/min |
| Speed Limitation | 0 | 5~15000 | mm/min |
| ManualSpeedLimitatio | 0 | 20~18000 | mm/min |
| Idle Run Speed | 0 | 20~18000 | mm/min |
| Back Speed | 0 | 100~6000 | mm/min |
| Reset Speed | 0 | 100~6000 | mm/min |
| Arc Transition | 0 | 0~1 | |

5.2.1 Start Speed: controller's start speed and stop speed of X axis and Y axis, unit: mm (or inch)/min; jump frequency, machine makers set proper start speed according to machine power, load and other factors. Usually there is no need to revise the parameter.

5.2.2 TimeMultiplyingPower (time multiplying power): multiplying power from start speed to top speed limitation, value is bigger, acceleration time is longer

- 5.2.3 Buff Speed (buffer speed): in order to reduce the shock from cutting machine run at high speed, set a lower buffing speed, usually for a machine with soft steel working table and high speed, If don't use the function, and can set it same as "speed limitation"
- 5.2.4 Speed Limitation: top cutting speed, unit: mm (or inch)/min
- 5.2.5 Manual Speed Limitatio: running speed in manual mode, unit: mm (or inch)/min
- 5.2.6 Idle Run Speed: running speed without load (G00 rapid point movement speed), unit: mm (or inch)/min
- 5.2.7 Reset Speed: speed of back to machine zero, unit: mm (or inch)/min
- 5.2.8 Back Speed: speed of backward, unit: mm (or inch)/min
- 5.2.9 Arc Transition: whether choose arc transition when corner, 1 is valid, 0 is invalid
- 5.2.10 speed down coefficient: speed down ratio at corner according to machine inertia, rigidity and other factors
- 5.2.11 speed adjustment angle: set it according to machine inertia, rigidity and other factors, when smaller than the angle, controller doesn't adjust speed.
- Note: speed parameters and machine characteristics have close relations.

5.3 Enter Ctrl (control) interface

5.3.1 Edge Pierce: 0 is not to choose, 1 is to choose (when pierce point, a tip will appear "LocalPie (pierce at current position), EdgePier (out edge pierce), NoPierce")

5.3.2 No Pretreat Graph: usually firstly treat program, measure figure's max/min value,

when program is huge, it takes longer time to treat, then can choose No Pretreat Graph (figure), set figure's max/min value in advance, controller draws and cuts at the same time

5.3.3 XZ/YZ Common Side: 0 is X/Z synchronizes movement control, 1 is Y/Z synchronize movement control, also dual drive

5.3.4 external remote control: 1 is to choose external remote control

5.3.5 Metric/British Syste (metric/British system): 0 is not to choose, 1 is to choose. When choose 0 metric system, length, speed and coordinate are all mm, and can run British system program (G20), but show metric system (mm). When choose 1 British system, length, speed and coordinate are all inch, and can run metric system program (G21), but show inch

5.3.6 External Remote Cont (external remote control): use it to choose 1, no is 0

5.3.7 G41/G42 Detect Valid: check whether compensation (G41/G42) is right. When error is not serious, choose 0, tip error line, but no alarm, continue to run program

5.3.8 Torch Pneum Lift Opt (torch pneumatic lifting): cut thin plate, pneumatic lifting is better than auto torch height controller, choose 1, and torch down is valid, torch up is invalid, torch down is in keep state.

5.3.9 External Limit Valid: many small cutters are so simple without external hardware limit,

| ParaName | Value | ValRange | Unit |
|----------------------|-------|----------|------------|
| Edge Pierce | 0 | 0~1 | 0 No/1 Yes |
| No Pretreat Graph | 0 | 0~1 | 0 No/1 Yes |
| XZ/YZ Common Side | 0 | 0~1 | 0 No/1 Yes |
| External Remote Cont | 0 | 0~1 | 0 No/1 Yes |
| Torch Pneum Lift Opt | 0 | 0~1 | 0 No/1 Yes |
| Metric/British Syste | 0 | 0~1 | 0 No/1 Yes |
| G41/G42 Detect Valid | 0 | 0~1 | 0 No/1 Yes |
| External Limit Valid | 0 | 0~1 | 0 No/1 Yes |
| Collision Detection | 0 | 0~1 | 0 No/1 Yes |
| Torch Up after Pause | 0 | 0~1 | 0 No/1 Yes |
| Smooth Optimization | 0 | 0~3 | 0-noLevel |

🔥 Explain 0: Cancel, 1: Select

 SpeFunc Upload Para
 Default Dnload Para

Exit
System
Speed
Ctrl
Craft
Switch
Save

choose 0 to cancel hardware limit input to avoid unnecessary hardware fault

5.3.10 Collision Detection (torch collision detection): if equipment has torch collision detection (P1 uses + limit input), choose 1, the input is normally closed, if torch collision (off), stop (alarm).

5.3.11: Torch Up after Pause: if need torch to move up after pause, choose 1

5.3.12 Smooth Optimization: optimize program to avoid machine shaking caused by frequent up and down, arc fit for small section, 1~3 level option, 0 NO. This function is mainly used for figure files made by non-conventional CAD software, most are art figures or letters, smooth optimization affect cutting, please choose this function according to need.

5.4 Enter Craft interface

(1) Flame parameters

| ParaName | Value | ValRange | Unit |
|---------------------------|---------|-----------------|------|
| Ignition Delay Time | 0.500 | 0.000~20.000 | S |
| Preheat Delay | 2.131 | 0.000~999.999 | S |
| TorchUp Delay Time(M70) | 1.000 | 0.000~10.000 | S |
| TorchDown Delay Time(M71) | 0.800 | 0.000~10.000 | S |
| PierceUp Delay(M72) | 1.000 | 0.000~10.000 | S |
| PierceDownDelay(M73) | 0.800 | 0.000~10.000 | S |
| Pierce Delay Time | 0.500 | 0.000~10.000 | S |
| Idle Run Raise Torch | 100.000 | 0.000~10000.000 | mm |

5.4.1.1 Ignition Delay Time: flame cutting, when M20, open high pressure ignition switch delay time

5.4.1.2 Preheat Delay Time: pierce preheat time, unit: s, cut workpiece every time, preheat delay time is 100s, if preheat is ok, can press [Start] to end preheat, and automatically save preheat time parameter, after start to preheat, if preheat time is not enough, can press [Pause] to add 100s to preheat

5.4.1.3 TorchUp Delay Time (M70): torch up delay time; unit: s

5.4.1.4 TorchDown Delay Time (M71): torch down delay time; unit: s

5.4.1.5 PierceUp Delay (M72) (pierce torch up delay time): unit: s

5.4.1.6 PierceDownDelay(M73): pierce torch down delay time, unit: s

5.4.1.7 Pierce Delay Time: flame cutting pierce M07, open cutting oxygen then torch down

5.4.1.8 Idle Run Raise Torch: idle run distance, unit: mm

5.4.1.9 Climb option: cut thick plate to avoid splashing steel slag after pierce, It is available that after pierce torch cut and down instead of directly down from the pierce height to cutting height.

(2) Plasma parameters

| ParaName | Value | ValRange | Unit |
|--------------------------|--------|----------------|------|
| Torch Locate Delay | 0.200 | 0.000~2.990 | s |
| TorchUp Delay Time(M70) | 0.800 | 0.000~10.000 | s |
| TorchDown Delay Time(71) | 0.800 | 0.000~10.000 | s |
| Arc Voltage Check | 0 | 0~1 | |
| Location Check | 0 | 0~1 | |
| Pierce Delay Time | 0.300 | 0.000~12.000 | s |
| Arc On Delay Time | 0.100 | 0.000~10.000 | s |
| Dista corner THC off | 10.000 | 0.000~1000.000 | |
| Arc off Distance | 10.000 | 0.000~90.000 | mm |
| Crawl | 0 | 0~1 | |
| delay time of auto THC | 0.000 | 0.000~10.000 | s |

Explain Torch location delay time

 SpeFunc Upload Para
 Default Unload Para

Exit
System
Speed
Ctrl
Craft
Switch
Save

5.4.2.1 Torch Locate Delay (torch location delay time): when plasma torch locates, torch down till receive torch location switch signal, then stop, start location time and torch up, if choose "location check valid", torch location delay is invalid.

5.4.2.2 TorchUp Delay Time (M70): unit: s, note: in order to be convenient, torch up/down is separate for plasma and flame

5.4.2.3 TorchDown Delay Time (M71): unit: s

5.4.2.4 Arc Voltage Check: this option is to decide whether check arc voltage. 1 is to choose arc voltage check, when strike arc, check arc voltage feedback and monitor it when run. When arc voltage feedback is broken, controller will pause and tip. Usually arc voltage check is for cutting thick plate. 0 is not to choose, after open strike arc switch, start to cut after pierce delay, don't check arc voltage feedback. The function is available based on plasma power having feedback signal of arc-strike success. And connect this signal with the port of controller's "plasma arc check", most of plasma powers have this function and the input signal is DC24V.

5.4.2.5 Location Check: when execute M07, 1 is to choose torch location, 0 is not.

5.4.2.6 Pierce Delay Time: after striking arc, controller starts to cut after pierce delay time

5.4.2.7 Arc On Delay Time: strike arc delay time

5.4.2.8 Dista corner THC off (turn off THC at corner): at corner speed changes (changing arc voltage may make torch to collide plate), so controller will automatically turn off THC near corner, automatically open after corner, unit: mm

5.4.2.9 Arc off Distance (arc off in advance near the end): closed curve has a common point of start point and end point, easy to over burn, this option is to automatically turn off arc voltage and THC near the end

5.4.2.10 Crawl: after pierce, torch doesn't need to move down the setting position; it moves down and runs at the same time

5.4.2.11 delay time of auto THC: after striking arc, run a distance, then turn on auto torch height controller to avoid unsteady running after striking arc

5.4.2.12 change between 2 cutting modes

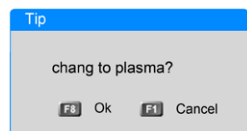

Chapter 6 Diagnosis

| | | | | | | | | |
|--------------------------------------------------------------------------------------------------------------|-------|-------|-------|-------|-------|------|------|------|
| Output | M10 | M12 | M14 | M16 | M38 | M20 | M22 | M24 |
| | 1 | 0 | 0 | 0 | 0 | 0 | 0 | 0 |
| Input | +Lim | -Lim | X0 | Y0 | Arc | Stop | Paus | Loca |
| | 1 | 1 | 1 | 1 | 1 | 1 | 1 | 1 |
| | Spare | Spare | Spare | Spare | Start | BIT2 | BIT1 | BIT0 |
| | 1 | 1 | 1 | 1 | 1 | × | × | × |
|  Infor <input type="text"/> | | | | | | | | |
| Exit LeftMo RightM Set 1 Set 0 Revers Set invalid Set normal state | | | | | | | | |

Main function: check the state of input/output port to judge whether controller is normal. Set normally-open and normally-close state and invalid input port based on machine detail. Output diagnosis: [LeftMo] (move left), [RightM] (move right) to choose output, [Set 1], [Set 0] and [Revers] (reverse) to change output state. Input diagnosis: change outside input state and check whether they are normal. Save input state to be normal state.

[Input state of flame mode]:

- M10: acetylene (gas) valve switch (3-pin terminal COM, 01 connect normally open contact output)
- M12: cutting oxygen valve switch (3-pin terminal COM and 02 connect normally open contact output; pin11 of 25-pin port is (OH2) normally closed contact output, pin6 (OH1/OH2/OH3/OH4) relay public)
- M14: torch up switch (pin7 of 25-pin port is torch up (OH3) normally open contact output, pin8 is normally closed output)
- M16: torch down switch (pin19 of 25-pin port is torch down (OH4) normally open output, pin20 is normally closed output)
- M38: torch height controller auto control port (pin21 of 25-pin port and 24V form 24V loop)
- M20: ignition switch (pin9 of 25-pin port and 24V form a 24V loop)
- M22: spare output (pin22 of 25-pin port and 24V form a 24V loop)
- M24: spare output (pin10 of 25-pin port and 24V form a 24V loop)

[Output state of plasma mode]:

M38: torch height controller auto control port (pin5 of 25-pin port is torch height controller corner signal (torch height controller auto/man switch) (OH1) relay normally open contact output)

M12: strike arc switch (pin18 of 25-pin port is arc striking signal relay (OH2) normally open contact output, pin6 is (OH1/OH2/OH3/OH4) relay public port)

M14: torch up switch (pin7 of 25-pin port is torch up (OH3) normally open contact output, pin8 is normally closed contact output)

M16: torch down switch (pin19 of 25-pin port is torch down (OH4) normally open contact output, pin20 is normally closed output)

M10: spare port (3-pin terminal, COM, 01 connect normally open contact output)

M20: in plasma mode, when ignition delay time is 0, always on (change switch of flame/plasma), ignition switch (pin9 of 25-pin port and 24V form 24V loop)

M22: spare output (pin22 of 25-pin port and 24V form 24V loop)

M24: spare output (pin10 of 25-pin port and 24V form 24V loop)

[Output diagnosis instruction]:

+Lim (+ Limit): external + limit (normally closed stroke switch), when choose torch collision check, the pin is torch collision check point

-Lim (+ Limit): external – limit (normally closed stroke switch)

X0 (machine X0)/torch up: two functions, when reset direction is valid, it' s X0 machine original point; or it' s external manual torch up switch (no lock, normally closed)

Y0 (machine Y0)/torch down: two functions, when reset direction is valid, it' s Y0 machine original point; or it' s external manual torch down switch (no lock, normally closed)

Arc (arc voltage): external successful arc striking signal (usually off, connect ground when successful arc striking)

Stop (emergent stop): external emergent stop switch (normally closed)

Paus (pause): external pause switch (normally closed)

Loca (location): initial location before plasma pierce

The left are external remote control

Communication port: 9, 10, 11, 12, 13 external start, 15, 24V ground

Input [set invalid] [set normal state] of DIAGNOSIS

In the interface of DIAGNOSIS, move the blue checked box to the input box, 16 input ports in total, the last 3 ports are invalid as default (invalid input point is a grey X), users can press [F7] to set invalid input based on personal request, and set normally-open and normally-closed state according to wire connection of the machine, press [F8] to set it to be normal state, save invalid input and normal state. Usually don' t change the normal state.

Chapter 7 Figures library

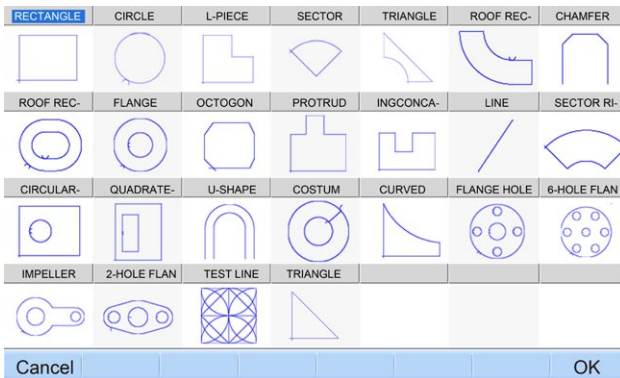

The controller offers 25 figures, press [↑][↓][←][→] to choose, press [Enter] to confirm. Then you can input parameters of that figure.

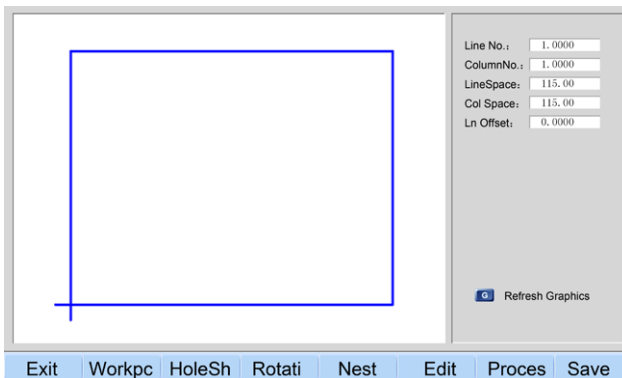

[Workpc] (workpiece): cut according to workpiece, inside part is valid

[HoleSh] (holeshape): cut according to holeshape, outside part is valid

[Rotati] (rotation): input rotation angle, press [Enter] or F8 to display new figure with rotation angle, the angle is anticlockwise



[Nest]: nest figure after setting parameters

[Edit]: the same of Edit function

[Grid]: new function for rectangle workpiece, after nest, there is a option of Grid, press X to choose it, it' s zip cutting. If no the option, it' s a common nest cutting.

Note: grid cutting has no kerf compensation; compensation value is set in the figure by you. For example, a figure of 100 X 200, kerf compensation is 2, you need to set 102 and 202 [save side]: this function is only available for grided rectangle, press Y to choose (save left/bottom/double side or no save side), press Y to show an option at the screen right-bottom corner, and the left figure will change. No selection is no side save.

[Proces] (process): after setting parameters to the figure and press G to refresh new figure, press [Proces] (process) to cutting interface

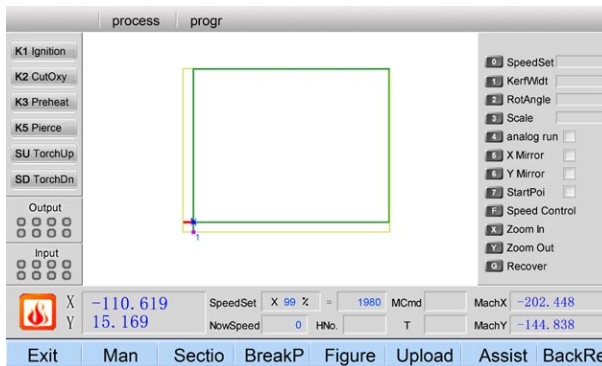
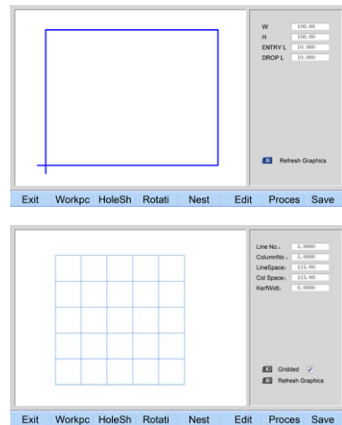

[Save]: after revising parameters and press [G] to refresh the figure, press [Save], the same as save function of [Edit] function

Chapter 8 Help function

[Interface introduction]:

- 0 Product: information of product and company
- 1 Auto: help information of Auto function
- 2 Man: help information of Man (manual) function
- 3 Edit: help information of Edit function
4. Paramete (parameter): help information of Parameter function
5. Diagnosi (diagnosis): help information of Diagnosis
6. Figure: help information of Figure library
7. Exit: help information of Exit

Chapter 9 Cutting control code

Cutting programs are made of codes. Programs from CAM, figure library and others must fit definitions and formats of this controller' s codes.

📍 Coordinate

This controller has 2 axes. The user can define X and Y axis and directions.

The common definition: the axis parallel to the controller' s panel is X axis, the other axis is Y. When the user faces to the controller, right is X axis positive direction, forward is Y axis positive direction.

Coordinate definition should be set by the maker according to user' s request.

User can ask maker' s technician to change coordinate axis and direction.

Steel plate' s length and width also can be set, X direction is length, Y direction is width, length can be longer than width, and length can also be shorter than width.

📍 Program code

G, M: write two digits, G00, G01, G02, and G03 are modal codes, next G00, G01, G02 and G03 can be omitted.

F: speed code, unit is mm/min

X, Y: end point coordinate of a program. It' s absolute coordinate when absolute mode (G90), it' s an incremental coordinate when incremental mode (G91).

U, V: end point coordinate increment of program section, it can omit without movement

I, J: relative coordinate of center of circle for start point, it can' t omit for circle arc

L: times of cycle, delay time

Note: X, U and Y, V can' t appear in the same program section

Only field name without value is not allowed

In the same program line two M codes are not allowed

In the same program line two G codes in the same group are not allowed

For coordinate (absolute or increment), unit: mm, 3 digits after decimal point, integer without decimal point

Max. arc radius is 134217 mm

Codes can be separated by "space" or no separator

Write M60 before program ends to turn off all outputs

When program ends, should write M02, write M30 + "Enter" in a new line

📍 G code

G00: point movement

Format: G00 X [/U] Y [/V]

Rapid point movement (interpolation), move to the end point along an oblique line at the idle-run speed

G01: straight line interpolation

Format: G01 X [/U] Y [/V] F

Straight line interpolation cutting, move to end point at current speed

```
eg. G92 X0 Y0
G00 X200 Y95
G01 X80 Y235
(or G01 U120 V145)
M02
```

- torch current position
- torch expectant position

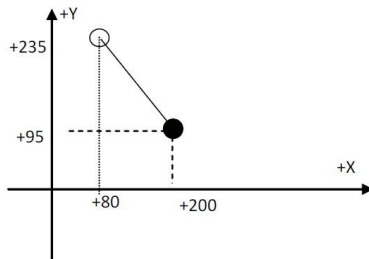

G02: clockwise circle interpolation (anticlockwise)

Format: G02 X [U] Y [V] I J F

Clockwise circle interpolation, move to circular arc end point in anticlockwise direction at current speed.

Note: cutting as straight line when radius is smaller than 1mm

G03: anticlockwise circle interpolation (clockwise)

Format: G03 X [U] Y [V] I J F

Anticlockwise circle interpolation, move to circular arc end point in clockwise direction at current speed.

Note: cutting as straight line when radius is smaller than 1mm

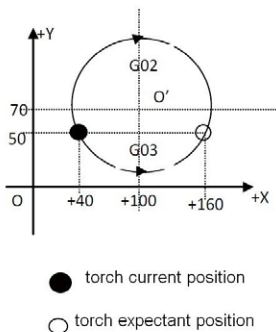

```
eg. (G02):
G92 X0 Y 0
G00 X40 Y50
G02 X160 V0 I60 J20
G28
M02
eg. (G03) :
G92 X0 Y0
G00 X40 Y50
G03 X160 V0 I60 J20
(or G03 X160 V0 R63.25)
G28
M02
```

Note: I, J are incremental values from the circle center to the starting point in X axis and Y axis.

R is the radius of the circle (R is positive value, when arc ≤ 180 degree, R is radius)

If I, J are specified, don't use R; Vice versa

G26, G27, G28 back to reference point

This code can make the torch automatically back to the reference point

Format: G26 X axis back to reference point

G27 Y axis back to reference point

G28 X, Y axis back the reference point the same time

G22/G80 cycle

This code can cycle program, G22 is the start of cycle, times of cycle is L. G80 is the end of cycle as well as nested cycle with less than 5 layers. G22 and the closest G80 are a cycle.

Format: G22 Ln (times of cycle)

Cycle content
G80 (cycle end)

G40: cancel radius compensation

Format: G40

Cancel current radius compensation, it and G41 or G42 are a pair.

G41: set left radius compensation

Format: G41

G42: set right radius compensation

Format: G42

Format: G41 (or G42) Rn

Compensated program section

G40

Note: G41 is to compensate the half of the flame diameter at left along the cutting track.

G42 is to compensate the half of the flame diameter at right along the cutting track.

G40 is offset over

Because the cutting compensation is automatically finished, so there must be G00 fast location sentence before G41 and G42 to promise the cutting nozzle to adjust the position; after G40 cancels the cutting compensation, a G00 sentence is needed to adjust the position back.

G90: absolute coordinate mode (default)

Format: G90

Program is absolute coordinate mode, only has relationship with X, Y coordinate

G91: incremental coordinate mode

Format: G91

Program is incremental coordinate mode, only has relationship with X, Y coordinate actual values.

Eg.1: G92 X0 Y0

G91 // relative coordinate

G00 X100 Y100 // fast locate to (100, 100), equal to G00 U100 V100

G01 X500 Y100 // straight line cut to (600, 200), equal to G01 U500 V100

Eg. 2: G92 X0 Y0

G00 X100 Y100 // fast locate to (100, 100)

G01 X600 Y200 // straight line cut to (600, 200)

G92: set workpiece coordinate

Format: G92 X Y

Set current point' s coordinate in workpiece coordinate (cutting coordinate or program coordinate). The program is only used one time and it' s in the first line.

G code groups

| Group | Code |
|-------|---------------------|
| 1 | G90,G91,G40,G41,G42 |
| 2 | G00,G01,G02,G03 |
| 3 | G04,G80,G81,G92 |

Group 1 codes and group 2 codes can write in the same program line, and group 1 codes has higher priority than group 2 codes, in the same program line, group 1 codes firstly run Group 2 codes are modal codes, if they appear one time, next time they can omit Group 1 codes and other 2 groups appear in the same program; Group 3 and other 2 groups appear in the same program.

📍 M code

M00: program pause, press [Start] to continue the program

M02: program end

M30: same as M02

M10/M11: gas (acetylene) valve switch, M10 (on), M11 (off)

M12/M13: cutting oxygen valve switch, M12 (on), M13 (off)

M14/M15: torch up switch, M14 (on), M15 (off)

M16/M17: torch down switch, M16 (on), M17 (off)

M24/M25: spare switch, M24 (on), M25 (off)

M20/M21: ignition switch, M20 (0), M21 (off)

M07: pierce cycle (enter M07, can' t back, can move the torch)

M08: close cutting cycle

Flame cutting as below:

M07

1. If gas (acetylene) valve close, then open gas (acetylene) ignition;
2. torch down (torch delay time, M71);
3. open preheat oxygen valve, preheat delay time start, if preheat time is not enough, press [Pause], preheat delay time automatically increase 150s, if preheat is OK, press [Start], over preheat delay time, automatically save preheat time as a parameter.
4. torch up (pierce torch up delay time, M72)
5. open cutting oxygen valve (M12), pierce delay time, torch down (M73)
6. open torch height controller (M38), run next program

Plasma cutting as below:

M07

1. torch down (torch delay, M71)
2. if choose "pierce location valid" , torch down till touch low limit position switch, then stop, torch up, pierce location delay time, then torch stops

3. open arc-strike switch
4. check "arc voltage" signal, if choose "arc voltage check (0)", then doesn't check arc voltage, after successful arc-strike, pierce delay
5. open torch height controller (M38), run left program

M08 close cutting cycle

Flame cutting as below:

1. close cutting oxygen (M13):
2. close torch height controller (M39)
3. torch up (M70)

Plasma cutting as below:

1. close arc voltage switch
2. close torch height controller
3. torch up (M70)

M50 pierce

1. torch up (M72), no this movement when plasma cutting
2. open cutting oxygen (M12); or plasma strike arc, check "arc voltage success" signal
3. torch down (M73), no this movement when plasma

M52 ignition cycle

Open gas (acetylene) valve (M10), open high voltage ignition (M20), ignition delay time, close high voltage ignition (M21)

M70 torch up cycle

At the start and the end of the program, torch up, and move to next cutting position: open torch up switch (M14), torch up delay time, close torch up switch (M15)

M71 torch down cycle

Used before pierce: open torch down switch (M16), torch down delay, close torch down switch (M17)

M72 pierce torch up cycle

Used after preheat, torch up a little to avoid steel slag blocking nozzle when open cutting oxygen. Open torch up switch (M14), pierce torch up delay time, close torch up switch (M15)

M73 pierce torch down cycle

Used after preheat and M72, open cutting oxygen, put torch at the cutting position, the reverse movement of M72: open torch down switch (M16), pierce torch delay time, close torch down switch (M17)

M75 torch location delay time

Torch down (M16), touch low limit position (input port 8 XXW), torch stop (M17), then torch up open (M14), torch location delay time, torch up stop

M60 total close

After M80 all output close

📍 Radius compensation

Radius compensation control code can remove the effect on the size by the kerf.

Kerf

Kerf width, not cutting radius, kerf value should be the same as the actual kerf width, and consider expansion and extraction by temperature.

Radius compensation lead-in/lead-out section: it's not cut-in/cut-out section. It means non-radius compensation change to radius compensation (lead-in section), and radius compensation change to non-radius compensation (lead-out), this section is usually G00, among two closed figures (from compensation to non compensation, then to compensation again), one G00 program section is OK; it's both lead-in section and lead-out section.

Compensation direction

Forward along cutting direction, left kerf compensation (G41) when compensate deviate left, right kerf compensation (G42) when compensation deviate right.

Sections transition types:

Shortened type: when cut inner angle, cutting track can't reach programming coordinate point, end in advance and go to next program to cut.

Lengthened type: when cut exterior angle of two straight lines, cutting track needs to extend forward over programming point

Transition type: when two sections are not straight lines at the same time, lengthened part is inserted a transition circular arc

Transition type of two straight lines: shortened type and lengthened type should avoid so big corner

From straight line to circular arc, from circular arc to straight line, from circular arc to circular arc: shortened type and transition type

Radius compensation in right way

After radius compensation, from the first cutting program section, deviate program outline a radius, till cancel radius compensation

If the workpiece needs good surface, pay attention to choose styles of cut-in/cut out section and length, as well as torch movement's effect on finished workpiece after lead-out

Choose proper position for cut-in/cut-out point, try to avoid affecting workpiece surface.

Chapter 10 Controller input/output connection

Controller's ports: XS12 input/output (DB25 pins), XS3(15 pins), XS8-RS232 serial port (15 pins to connect remote control)

10.1 Controller input principle

Common limit/start/pause etc. use mechanical switches, for avoiding interference, the normally closed contact of the mechanical switch is usually used, connection as below.

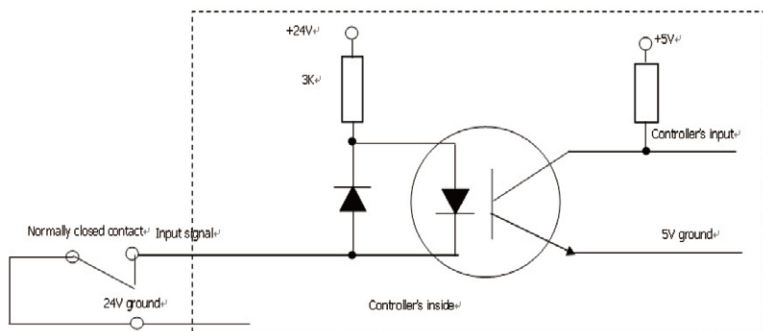

Notice:

1. Controller's emergent stop, pause and limit all connect normally open contact or normally closed contact.
2. After turning on the controller, the state of automatically checking the start is the controlling base.
3. If not connect external start switch, then corresponding start position should connect to 24V ground (similar with normally closed contact) or connect nothing (similar normally open contact).

10.2 Controller output principle

Control signal = 0 switch/relay switch on (+24V loop, low is valid, send signal)

Control signal = 1 switch/relay switch off (+24V no loop, cancel signal)

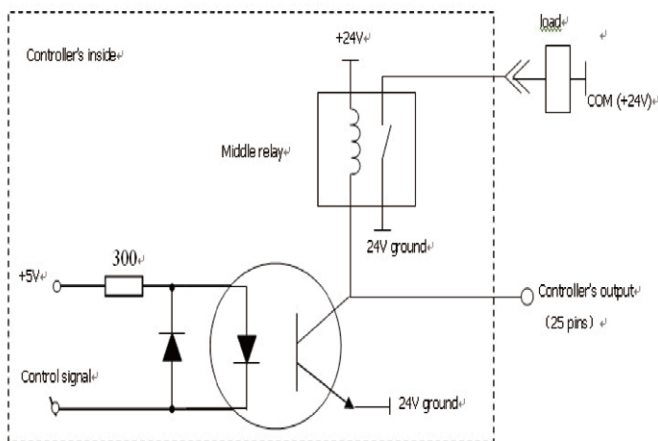

10.3 Input/output definition

10.3.1 DB25 input definition

| Definition | 25 pins | Instruction |
|--------------------------|---------|-------------------------------------------------------------------------------------------------------------------------------------------------------------------------------------------------------------|
| + limit | 1 | X/Y+ limit, + limit of two axis serial connection, high is valid, if don' t use, signal short connect to 24V ground, if don' t use limit, it can be used as torch collision check (normally closed) |
| - limit | 14 | X/Y- limit, - limit of two axis serial connection, high is valid, if don' t use, signal short connect to 24V ground |
| machineX0/ torch up | 2 | X0 mechanical original point, NPN type proximity switch, normally open, when reset direction is invalid, it' s outside torch up, high is valid, if don' t use, signal short circuit connect to 24V ground |
| machineY0/ torch down | 15 | Y0 mechanical original point, NPN type proximity switch, normally open, when reset direction is invalid, it' s outside torch down, high is valid, if don' t use, signal short circuit connect to 24V ground |
| Arc voltage check | 3 | Arc voltage check, low is valid, high before arc voltage connect |
| Emergent stop | 16 | Outside emergent stop, high is valid, if don' t use, signal short circuit connect to 24V ground |
| pause | 4 | Outside pause, high is valid, if don' t use, signal short circuit connect to 24V ground |
| location | 17 | Plasma torch location, lower limit |
| | 5 | Torch height controller corner signal (torch height controller auto/man switch) relay normally open contact output |
| | 18 | Start arc signal relay normally open contact output |
| | 6 | COM(OH1/OH2/OH3/OH4) isolation output public port |
| | 19 | Torch height controller torch (OH4) down normally open |
| | 7 | Torch height controller torch (OH3) up normally open |
| | 20 | Torch height controller torch (OH4) down normally closed |
| | 8 | Torch height controller torch (OH3) up normally closed |
| M10/M11 Or M38/M39 | 21 | flame: M38 torch height controller M38 on、M39 off plasma: M10 spare M10 on、M11 off |
| M20/M21 | 9 | M20 (on), M21 (off), flame: ignition switch, plasma: when ignition delay time is 0, open all the time (make as change switch of flame/plasma) |
| M22/M23 | 22 | spare |
| M24/M25 | 10 | spare |
| | 23 | corner (OH1) normally closed contact |
| | 11 | Cut oxygen (OH2) normally closed contact |
| 24V | 24 | +24V/1A power |
| 24V | 12 | +24V/1A power |
| 24V ground | 25 | 24V power ground |
| 24V ground | 13 | 24V power ground |

Notice

1. If the controller is used for plasma cutting/welding equipment, shielding wire must be used to connect the controller and the driver.
2. Input signal external connection is normally closed, invalid is on (low level), valid is off (high level).

10.3.2 DB15 input definition

| Definition | 15 pins | Instruction |
|-----------------------|---------|------------------------------------------------------|
| Torch collision check | 12 | Torch collision check signal |
| External start | 13 | The same function with the controller' s "Start" key |

10.3.3 15-pin motor port

1. differential signal

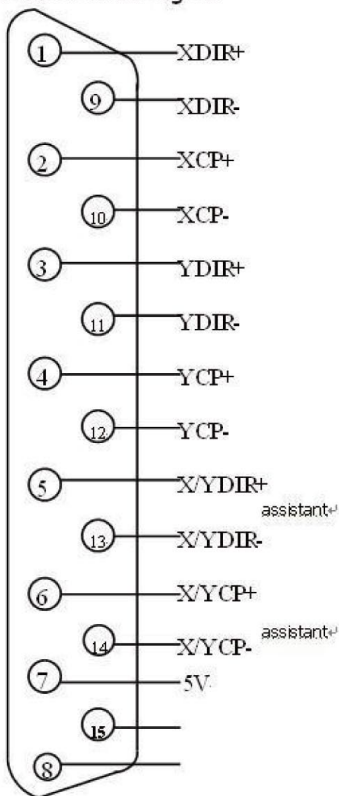

2. common anode connection

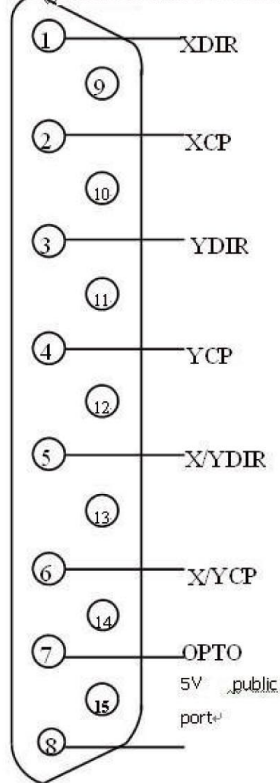

10.3.4 Flame cutting connection (DB15)

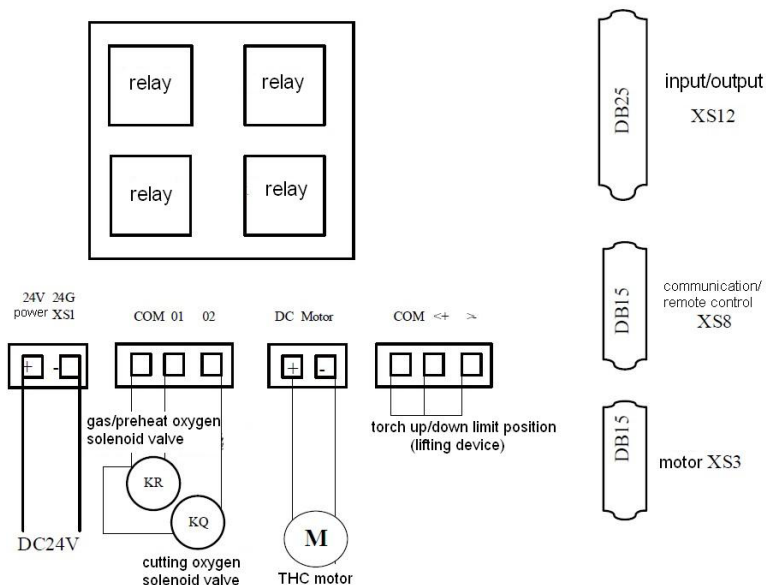

10.3.5 Plasma cutting connection (next page)

10.3.6 Flame/plasma integration

If flame/plasma integration is used, beside the above connection, a change switch K1 of flame/plasma is needed, connection as below,

- (1) KR acetylene (gas) magnetic valve
- (2) kQ cutting oxygen magnetic valve
- (3) If not connect acetylene (gas) magnetic valve, it's OK not to connect gas contact point
- (4) K1 is a relay (M20) of flame/plasma change-over

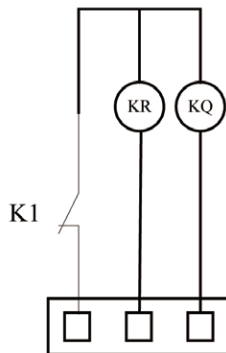

10.4 Output connection

10.4.1 Output principle

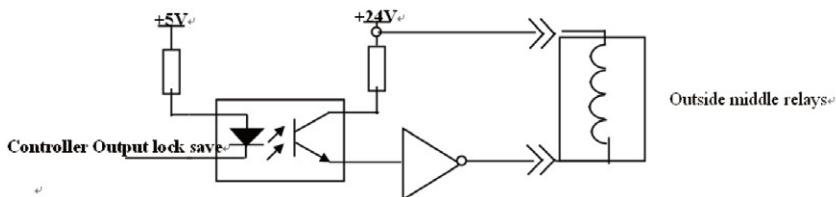

10.3.5 Plasma cutting connecton

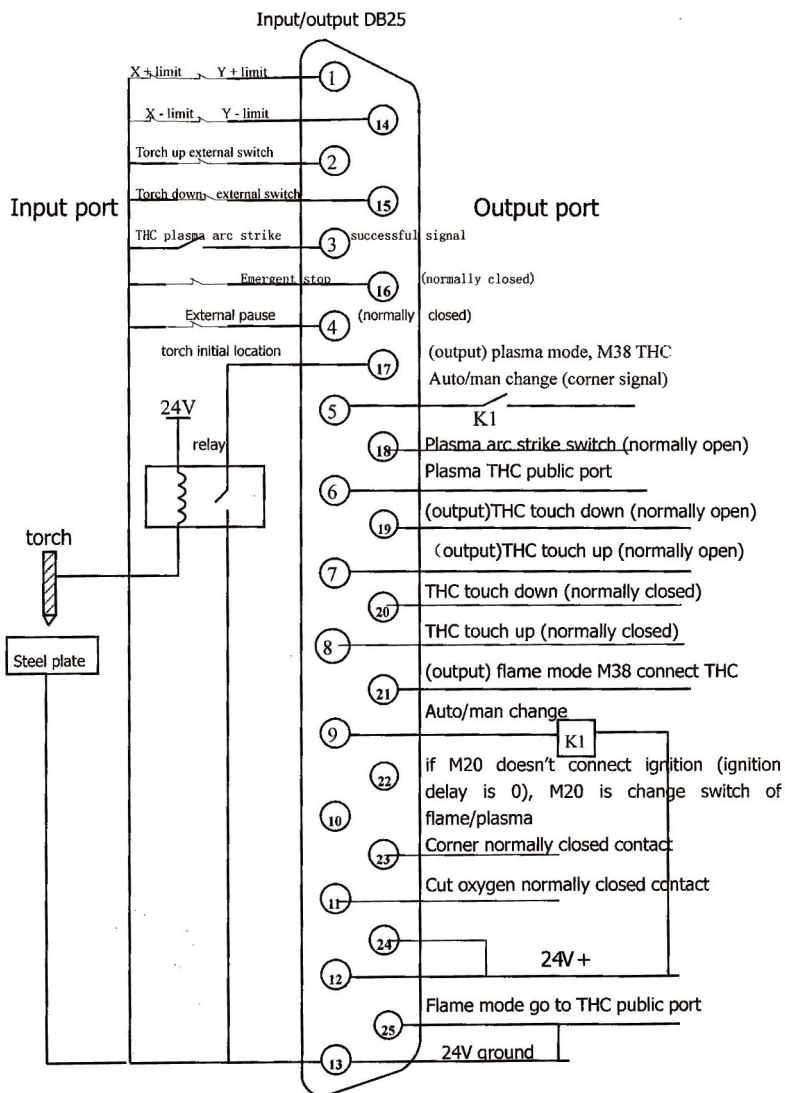

10.4.2 Notice

- 1) Controller needs an extra DC24V power supply
- 2) Controller needs DC24V power supply when using external input and output.

Chapter 11 Common faults and solutions

11.1 Controller fault

11.1.1 Controller can't enter control interface

Maybe the temperature of screen is too low. To turn on the controller and heat it, then turn on it again.

There is something wrong with hardware or hardware connection wire, or temperature of hardware is too low.

Maybe the controller has problem. Please ask help for our after-sale department.

11.1.2 Button fault

Maybe button is damaged, enter Diagn (diagnosis), keyboard

Maybe button shakes, enter Diagn (diagnosis), keyboard

Turn off the controller and turn on it again. If there are still problems, the controller is damaged. Please ask help for our after-sale department.

11.2 Operation fault

11.2.1 No movement in manual mode

There may be limit in this direction, or press emergent button.

Electrical gear numerator is 0 or denominator is 0.

Servo driver or step driver alarm.

Signal wire connection between controller and driver is improper.

11.2.2 Running distance error

Electrical gear ratio is improper. Change servo driver's electrical gear or controller's electrical gear.

The numbers of gear teeth or modules are improper. Rack's pitch is improper. Connection of two racks is improper.

Speed is over 8m/min (1 micrometer per equivalent).

Motor lock-rotor or miss-step (resistance is too big, or worse motor, or motor's power is too small).

11.2.3 Improper running speed

Ascending and descending curve parameter is improper (limiting speed should be bigger than top running speed, but should be below 8m/min; ascending and descending time is too long or too short, at most 5s).

Speed parameters are improper.

11.3 Program fault

11.3.1 Code and format problem

Program can be made by CAM and saved in the controller. Different CAMs and postprocessors make different program codes. It's possible that wrong grammar and code can't run. It's better to revise codes in the computer.

The controller can recognize coordinate in metric system, unit is mm, there are three digits after the decimal point.

Space can add between program codes as the separator, it's also OK not to have separator. The program must start with G92. G92 can't be in any place except the first line..

Absolute programming is default. You can use G90/G91 to change absolute/incremental coordinate, or use U and V to be incremental coordinate values of X and Y.

Running speed can use F code, but the value is integer instead of decimals.

The end of the program should have following code

M02 (main program ends)

When there is a problem to cut a whole circle, maybe it is caused by calculation tolerance (code tolerance), you can change a entry point or kerf value.

11.3.2 Problems when running program

Problem: After pause, restart, there is no pierce (sometimes)

Solution: pause, restart after backward

Max. program code is 99 sections when moving pierce point backward

11.4 Controller functions declaration



If there are incorrect and undetailed contents in the manual, the standard is subject to controller's functions.

Functions change or upgrade without notice.

Please contact after-sale for learning functions.

The latest manual (PDF) is available.

Appendix 1: Optional Parts

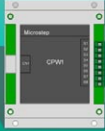
| | |
|--------------------------------------------------------------------------------------------------------|-------------------------------------------------------------------------------------------------------------------------------------------------------------|
|  <p>OPR1</p> | <p>wire remote control</p> <p>7 " true color display, touch operation</p> <p>1 Optional Parts</p> |
|  <p>CRF1</p> | <p>wireless remote control</p> <p>coordinate display and state display, AA battery power.</p> <p>2 Optional Parts</p> |
|  <p>CPW1</p> | <p>external operation keys</p> <p>external 16 keys, such as "Start", "Pause", "direction" ect.</p> <p>3 Optional Parts</p> |

Appendix 2: Torch height controller (SH-HC30) connection

1. Arc-voltage & capacitive torch height controller integration connection

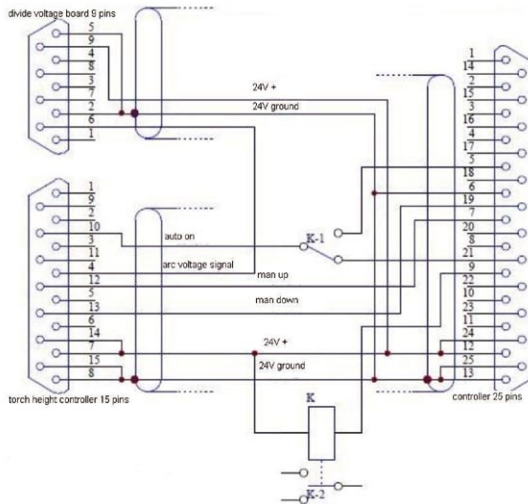

2. Voltage divider board (9 pins) definition

| No. | Property | Instruction |
|-----|----------|-------------------------------------------------|
| 2 | power | 24V ground, torch height controller power |
| 5 | power | 24V ground, torch height controller power |
| 6 | output | Arc voltage signal , plasma torch height signal |
| 9 | power | 24V +, torch height controller power |

3. Arc-voltage torch height controller connection

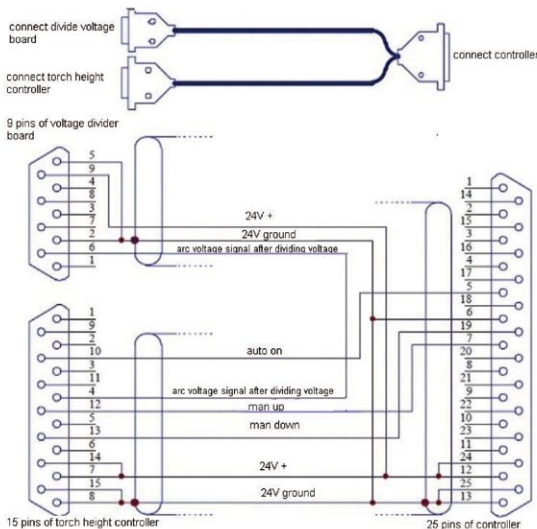

4. Capacitive torch height controller connection

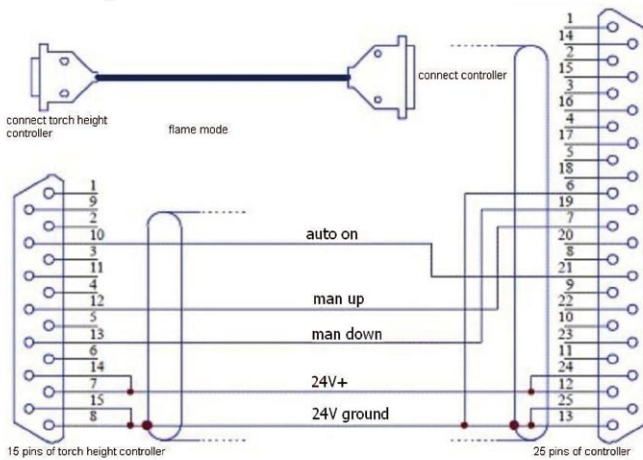

Appendix 3: remote control connection definition

| 15 pins of controller | | 15 pins of remote control | |
|-----------------------|------------|---------------------------|------------|
| No. | Definition | No. | Definition |
| 1 | 24V | 1 | 24V |
| 2 | TXD | 2 | RXD |
| 3 | RXD | 3 | TXD |
| 8 | 24G | 8 | 24G |
| 9 | I8 | 9 | EN |
| 10 | I9 | 10 | S1 |
| 11 | I10 | 11 | S2 |
| 12 | I11 | 12 | S3 |
| 13 | I12 | 13 | S4 |
| 15 | 24G | 15 | 24G |

Appendix 4 : CC-S1 upgrade operation

Function: controller can upgrade by U disk

Procedures:

- Copy upgrade files of CCS.UPD and CCS1.UPD in U disk and insert U disk into USB port
- in main menu, press "G", "G", "9", appear upgrade tip, press [F8] to confirm, enter upgrade interface in 5s
- If upgrade succeeds, screen will show 'successful upgrade, it' s ok to turn on it again" and buzzes one time.

If upgrade fails, screen will show "upgrade fails" and buzzes continuously.

- After upgrade, turn off the controller, pull out U disk, and turn on the controller again, the screen will show new version number.

CNC Cutting Controller CC-S1 User Manual



ISO9001: 2008 License number: 117 09 QU 0203-08 ROM

我们致力于每一步更完美!

We devote every step to be more perfect!

北京欣斯达特数字科技有限公司

Beijing Flourishing Start Digital Technology Co.,Ltd

Tel: 010-88909150 Fax: 010-88909271

Website: <http://www.microstep.cc>

START
SHAPHON

Microstep[®]

斯达特[®]

